

INSTRUCTION MANUAL

VSR5000

PROJECTION PEDESTAL & FILM TRANSPORT

Equipment Type 24-64027

Issue 2/98



STRONG INTERNATIONAL

a division of Ballantyne of Omaha, Inc.

4350 McKinley Street

Omaha, Nebraska 68112 USA

Tel 402/453-4444 • Fax 402/453-7238

CONTENTS

	Page No.
1. PREFACE	1
2. INSTALLATION	2
3. WIRING (Connection to Projector)	3
Interconnection Wiring Diagram	4
Motor Speed Control Settings	5
4. OPERATION	
Threading	6
Rewinding	8
5. MAINTENANCE	9
Description of Circuit Operation	9

PREFACE

THE VSR5000 is a vertical-reel, full feature length film transport and projection pedestal ideal for small projection booths. This unit requires less than eight square feet of floor space, and requires a projection port height of 59 inches (150cm) at 0° projection angle.

THIS SYSTEM is designed for use with reels 970mm outside diameter with 12.7mm hub spindles. These reels allow 4,500 meters of film to be made up on a single reel, eliminating the need for a second projector and notably reducing installation costs.

THE FILM FEED and take-up system is electronically regulated. This method considerably reduces mechanical breakdowns of the full-length film towers. At the same time, it reduces film slippage caused by traction and helps avoid the film breakage typical of traditional towers with mechanical take-up systems.

A SYSTEM of guide rollers allows the film to be fed smoothly through the VSR5000 to the projector and taken up on the operator-side reel.

THE VSR5000 is designed to allow the print to be rewound on the same pedestal. This is done by simply re-threading the film to the rewind rollers. The rewind is controlled using electronic speed control.

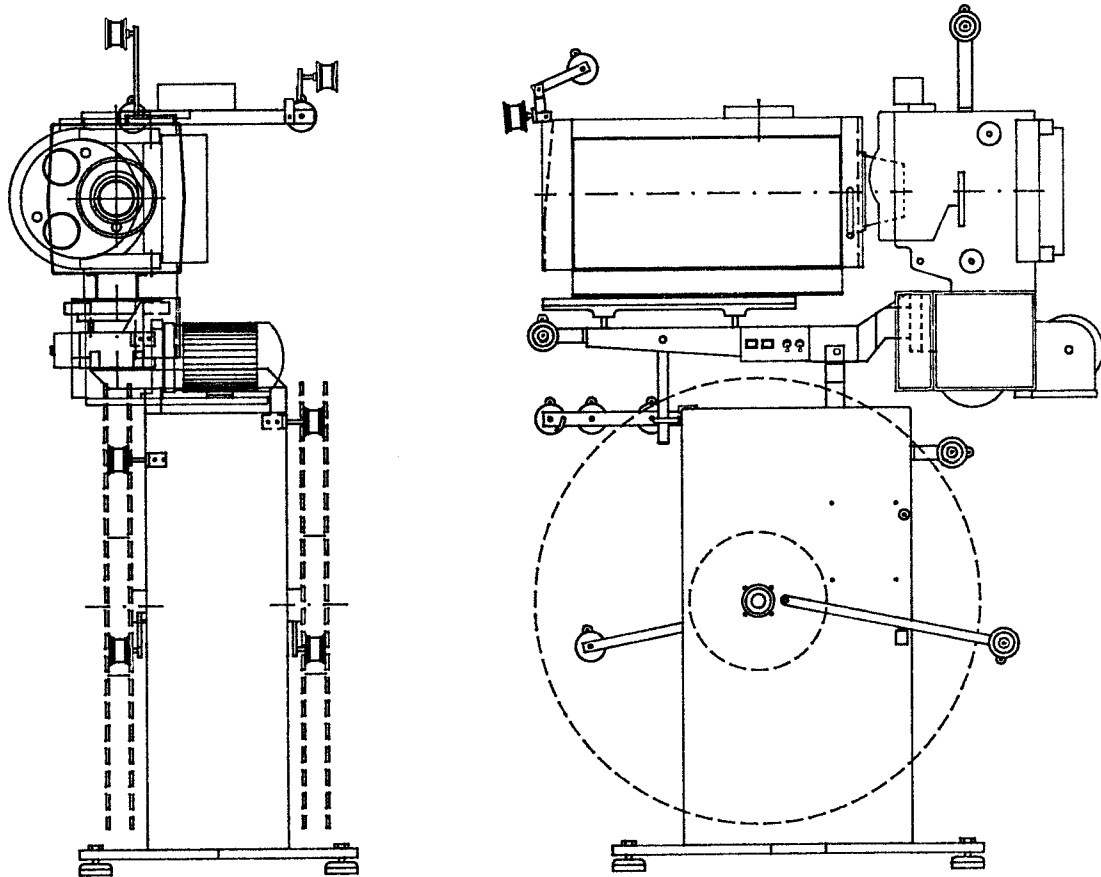

2. INSTALLATION

In order to accommodate shipping the VSR5000 Transport/Pedestal, the following parts have been sent unassembled:

- Box no. 1: Roller Assemblies (numbered from 1 to 7).
- Box no. 2: Base (Pedestal)
- Box no. 3: Arms or supports.

First, mount the lamphouse, soundhead, and projector to the lamphouse support casting as shown below. Mounting holes and hole centers are compatible to all lamphouses and soundheads currently manufactured by Strong International. Align the lamphouse to the projector per manufacturer's directions.

Next, install all the rollers and roller arms (see illustration).

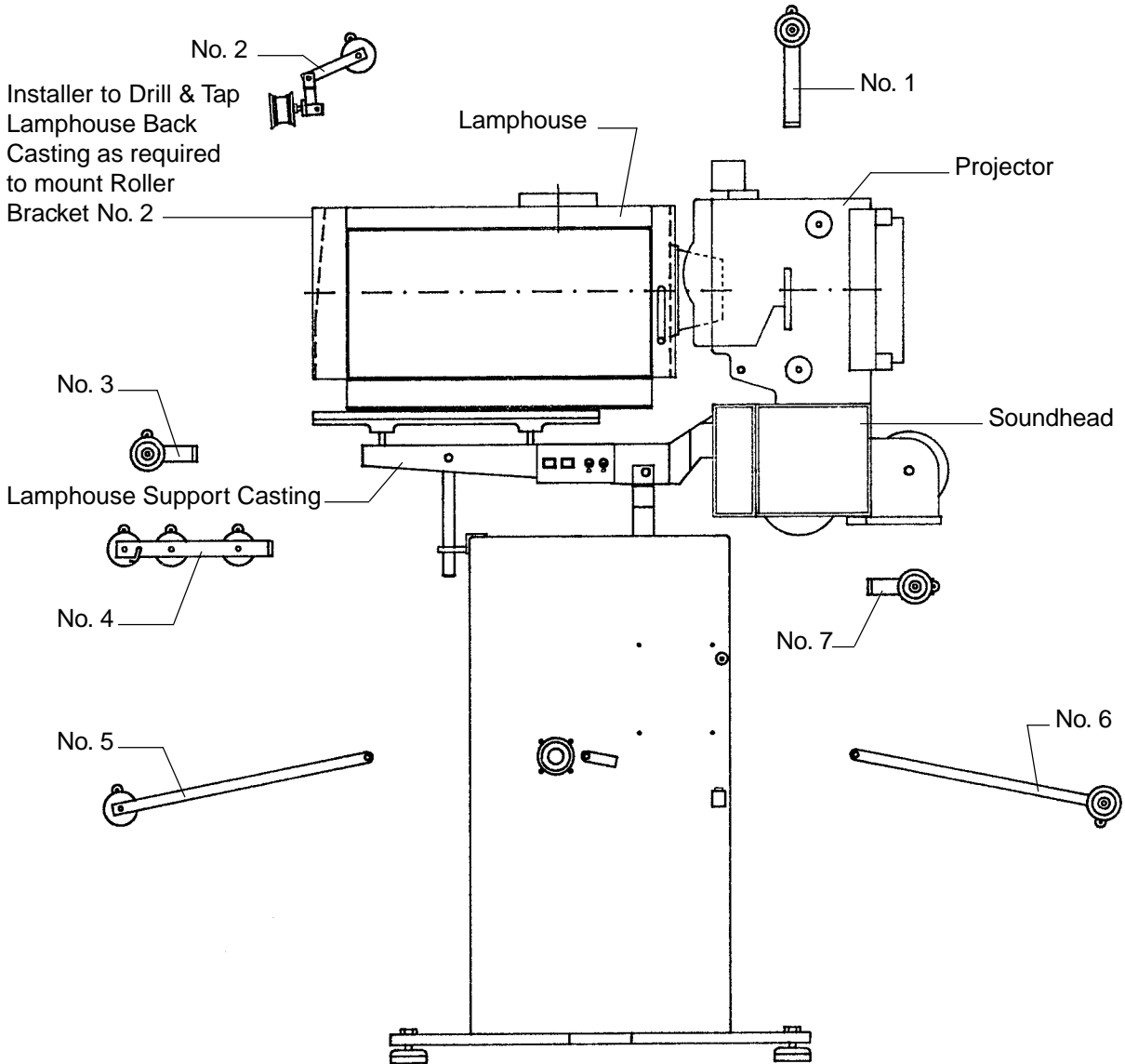

3. WIRING (Connection to Projector)

Once the VSR5000 has been assembled, connect it to the STRONG projector (see connection diagram following).

The VSR5000 responds to stop and start commands from the projector.

The VSR5000 is provided with two connection cables, one equipped with a floating 7-pin male connector and the other with a floating 14-pin male connector. These cables are connected to mating receptacles on the upper front, top surface of the pedestal. See the following wiring diagram for pin-out details.

4. OPERATION:

As already mentioned in the preceding section, the VSR5000 is designed to operate with (2) 4,500m reels with 12.7mm spindles.

Connect the power cord (front of unit) to a 220 volt, 50-60 Hz. grounded source.

Connect the switch located on the upper back part of the pedestal (see below illustration).

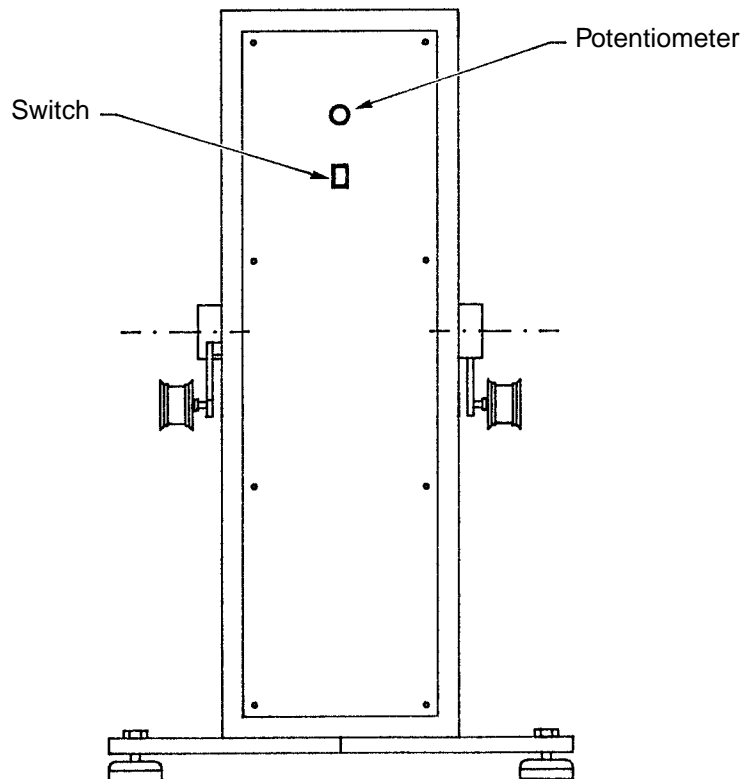

INTERCONNECTION WIRING DIAGRAM

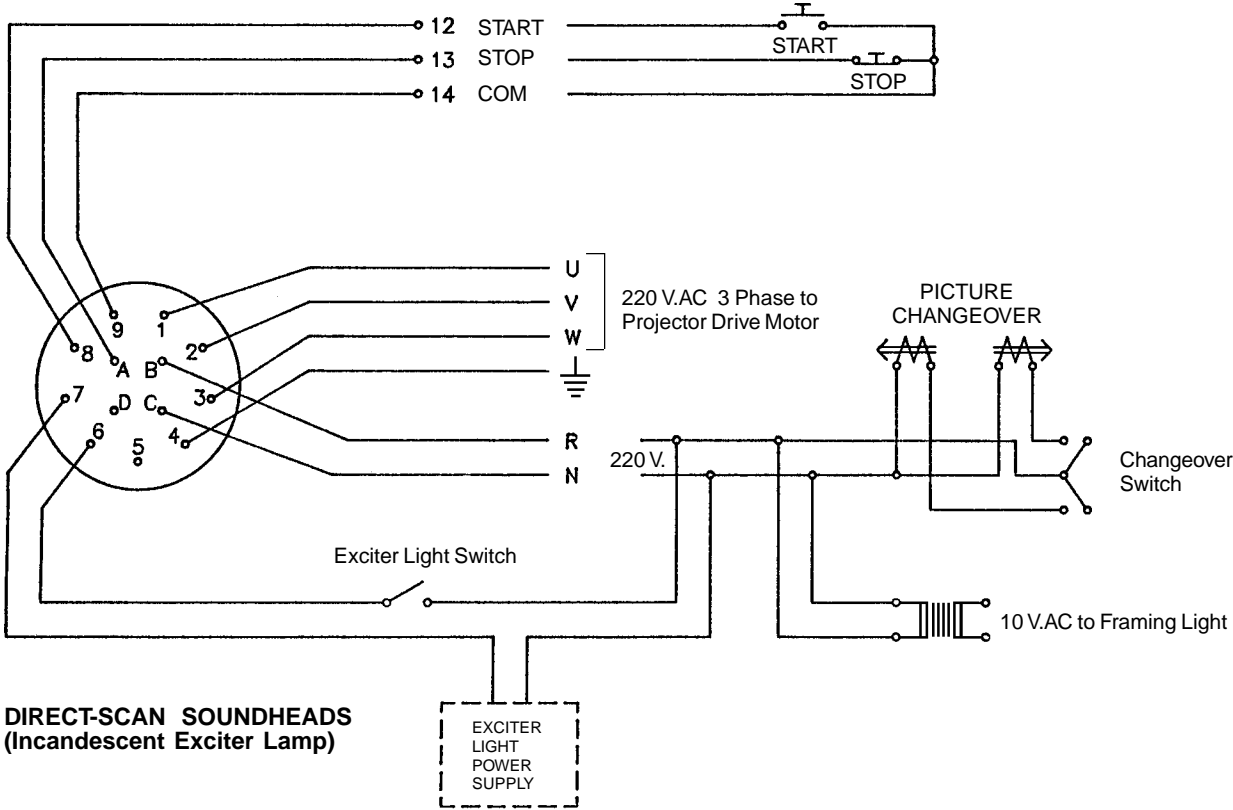

**DIRECT-SCAN SOUNDHEADS
(Incandescent Exciter Lamp)**

REVERSE-SCAN SOUNDHEADS (L.E.D. Exciter)

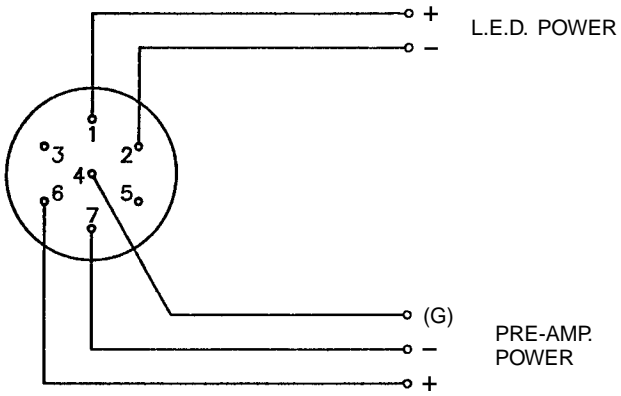

MOTOR SPEED CONTROL, Takeup & Payout

Each side of the pedestal incorporates a compensation arm for the purpose of maintaining constant tension on the film as it runs. These arms regulate the speed at which the film pays out and takes up. The theory of this mechanism is that the arm lifts (or falls) as the amount of film on the reels vary. As the arm lifts (or falls), the speed of the corresponding reel motor varies accordingly. Once the projector has reached a steady speed, the arm stabilizes its position and maintains a steady payout/takeup speed. Therefore, as the projector maintains speed, the film is constantly running at the correct payout/takeup speed without slack or excessive tension.

For the mechanism to operate correctly, it is necessary to make some preliminary adjustments to the electronic circuitry. Maximum voltage of the motors (payout and takeup) is about 200 V.DC, but the voltage must be set for the projector's requirements, which are nearly the same for all types of projectors.

Takeup

When the projector starts, the compensating arm on the operator-side reel falls and causes the motor speed to increase. This is done by the circuit board which controls the voltage regulation determined by the arm movement. The maximum speed (100 V.DC) is reached when the arm is in its lowest position, and the lowest speed (0 V.DC) when the arm is in its highest position.

Payout

The off-operator side reel must function in an opposite manner. When the film tension increases, the compensation arm falls downward, and vice versa. Maximum speed (0 V.DC) is reached when the compensation arm is at its highest position, and minimum speed (80 V.DC) at the arm's lowest position.

Voltage Settings

Voltage adjustments are made to the potentiometers on the *takeup* and *payout* circuit boards. The *takeup* board incorporates (1) pair of potentiometers to set the speed of the operator's side reel motor. The *payout* board includes (2) pairs of potentiometers (payout and rewind), and controls the speed of the off-operator side reel motor.

See the circuit board illustrations on pages 11 and 12. It is necessary to meter the motor voltage when adjusting the potentiometers: pins 15 & 16 on the *takeup* board, and pins 18 & 22 on the *payout* board. The compensation arms must be manually positioned (up or down) as *takeup* and *payout* adjustments are made; the speed control knob must be manually positioned (clockwise or counterclockwise) as *rewind* adjustment is made.

	<u>Minimum</u>	<u>Maximum</u>
Takeup	0 V.DC (Arm down)	100 V.DC (Arm up)
Payout	0 V.DC (Arm up)	80 V.DC (Arm down)
Rewind	2 V.DC (CCW)	200 V.DC (CW)

OPERATION WITH PROJECTOR

To project the film, pay out the film from the feed reel (off-operator side). Pass the film over the first No. 4 roller, under the No. 5 roller, and past the second No. 4 roller. Thread the film over the lamphouse using the uppermost No. 2 roller, and then over the No. 1 roller into the projector. Thread the film through the projector and soundhead. From the bottom of the soundhead, thread under the No. 6 roller and over the No. 7 roller to the hub of the take-up reel (operator's side).

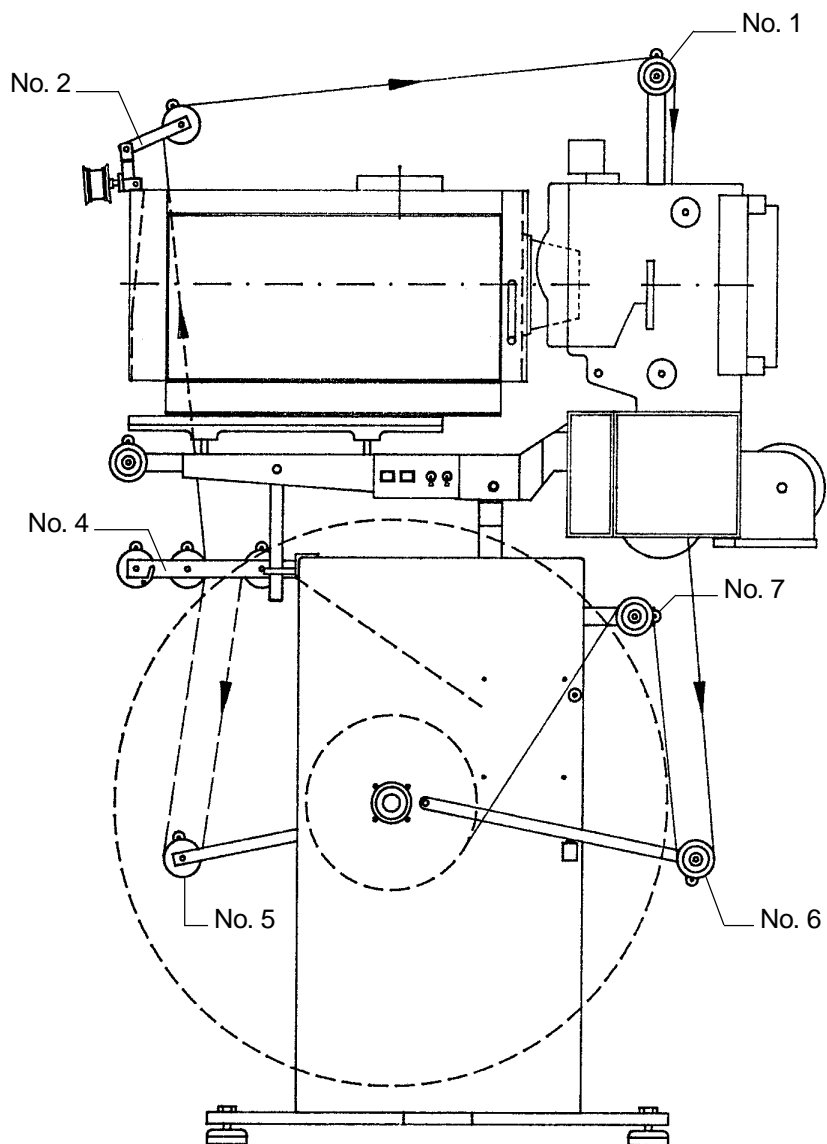

It is important to leave the take-up arms (No. 5 & 6) in a half-raised position, since if they are left down there is a risk of film breakage. Therefore, in order to avoid this, once the film is threaded, disconnect the VSR5000 (to disengage the arm brake), and manually rotate the reels to move the take-up arms into the proper position. Once this is done, reconnect the VSR5000. The unit should be energized when the projector is activated.

To start the feature, ignite the lamphouse, leaving the douser closed. Allow the arc to stabilize, and press the START button. Open the douser, and set the *sound* and the *picture changeover* switches in the ON position.

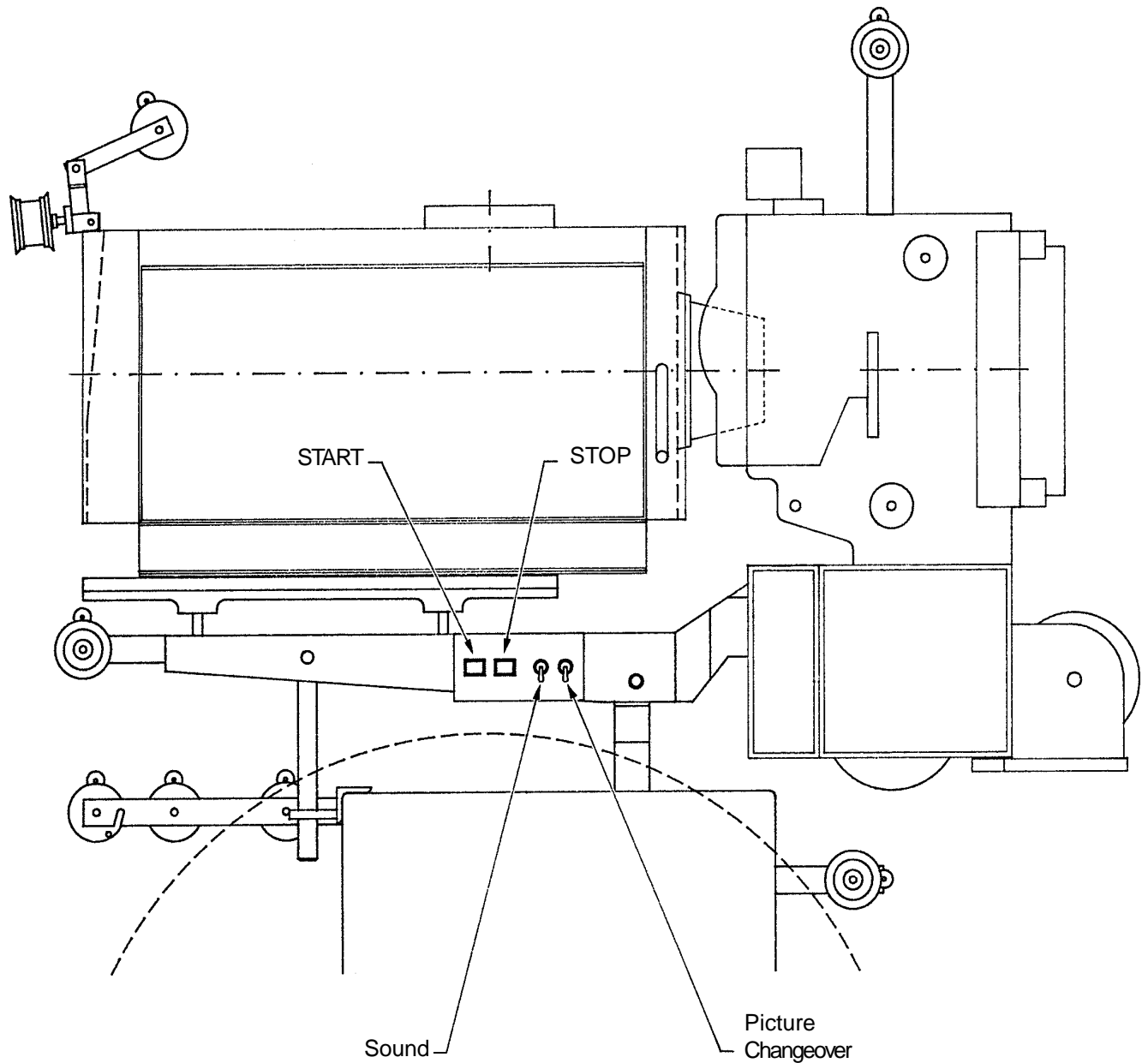

To stop the feature, close the lamphouse douser and set the *sound* and *picture* switches in the OFF position. Press the STOP button and extinguish the xenon bulb..

The feed and take-up speed of the film is electronically regulated. This electronic speed control helps avoid unnecessary stress on the film, and preventing breakage, by maintaining uniform tension on the reel.

Rewinding Film on the VSR5000

Once the entire print has been taken up onto the operator-side reel, it must be rewound prior to the next showing.

This is done by passing the film up from the take-up reel past roller No. 3. Loop the film over the lower No. 2 roller, and down to the No. 4 rollers. Pass the film under the two rear No. 4 rollers, over the front No. 4 roller, and down to the hub of the off-operator side reel.

Once the film is ready, the rewind speed is regulated by using the potentiometer (speed control) located on the back surface of the pedestal. First move the knob from OFF to ON. Once it has been activated, the speed can be regulated by rotating the knob *clockwise* to increase the speed, and *counterclockwise* to reduce speed.

Film breakage, or the end of the film, actuates a detector (located at the rearmost No. 4 roller) which automatically stops the rewinding of the print.

Once this operation has been completed, make sure that the speed control knob is in the OFF position.

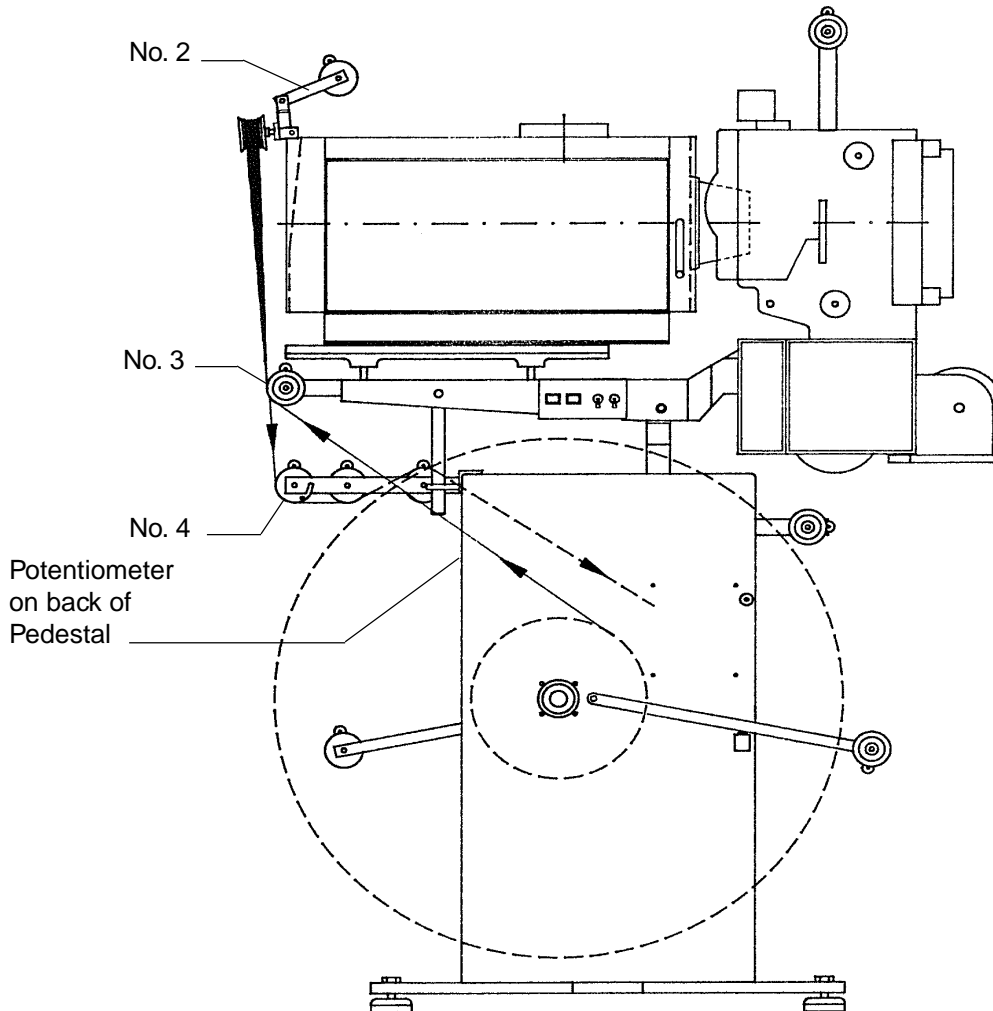

5. MAINTENANCE

Preventative maintenance of the VSR5000 involves only the cleaning and lubricating of the rollers and roller shafts.

When operation in projection mode is begun, the take-up arms of the VSR5000 must be raised half way. It is important to make sure that the take-up arms are in the proper position in order to avoid possible film breakage and equipment failures.

5.1 TROUBLESHOOTING

- a) VSR5000 is switched ON, but not running:
 - Check power source for adequate voltage
 - Check that REWIND is not active
 - Check for Start switch ON
 - Check for blown fuse
- b) Rewind not functioning:
 - Check indicator light for REWIND enabled
 - Check for Projector switched OFF
- c) Payout or takeup reel speed increases or decreases rapidly:
 - Check that control disc is in good condition
 - Check voltage settings (see page 5)
- d) Compensation arm is blocked in one direction; film payout has stopped:
 - Free the motor from the belt and continue operation

DESCRIPTION OF CIRCUIT OPERATION

A. Takeup Control Circuit

This circuit controls film takeup in Projection Mode. To control the speed of the DC motor driving the takeup reel, source voltage is modified. The motor, rated at 200 V.DC, never receives more than 100 V.DC when in operation. In design, as more film collects on the takeup reel, fewer motor revolutions are required.

The circuit consists of a high-luminosity diode (LED) and a light dependent resistor (LDR), separated by a disc with a small opening for light passage. The disc rotates a larger or smaller number of degrees depending on the weight of the takeup reel (large or small amount of film collected). The voltage supplied to the LED is constant, so regulation is dependent upon the voltage derived from the LDR (acting as a variable resistor).

B. Payout Control Circuit

Payout control operates in the same manner as takeup control, only in reverse. The payout motor speeds up as more film leaves the payout reel.

DESCRIPTION OF CIRCUIT OPERATION (continued)

C. Takeup Circuit Board

This assembly is designed to modify the speed of the takeup (operator's side) reel motor. It includes (2) potentiometers that regulate the DC voltage supplied to the reel motor. Settings are detailed on Page 5.

The circuit board has two voltage inputs: pins 17 & 18 are the general 220 V.AC inputs, and pins 12 & 14 receive 24 V.DC for relay activation from an external power supply. The board incorporates a small power supply for those board components which operate at 15 volts. This voltage might vary since it is not referenced to ground, but LDR voltage connections (3 & 4) are stabilized through voltage regulator U1.

Interlock microswitch connections (9 & 11) interrupt power to the reel motor and actuate the brake.

D. Rewind Control Circuit

This circuit consists of a switch, a lamp, and a variable resistor (speed control). The light glows when the switch is closed to indicate that rewind is enabled. The variable resistor has two settings only (maximum and minimum) used to start or stop the rewind.

E. Payout & Rewind Circuit Board

This assembly controls the speed of the (off-operator side) motor used for both paying out (in projection mode) and taking up (in rewind mode). The direction of motor rotation is determined by the setting of the rewind control connected to pins 7, 8, & 9.

The circuit board has two voltage inputs: pins 23 & 24 are the general 220 V.AC inputs, and pins 12 & 14 receive 24 V.DC for relay activation from an external power supply. Like the takeup board, LDR voltage (pins 3 & 4) are regulated through a U1 circuit. Interlock microswitch connections are pins 15 & 16.

F. Interlock

An interlock microswitch detects motion of film travel and stops the rewind and payout motors when film motion is interrupted (film break or run-out). The switch, mounted to the rearmost No. 4 roller, cuts the voltage to payout/rewind circuit when opened.

G. Frequency Unit

The frequency unit (Inverter Control) is used to obtain 220 V.AC three phase from a single phase source. The three phase connections to the soundhead motor are at terminals U, V, & W.

H. Relay Power Supply

This power supply furnishes voltage to the relays whose coils are actuated by 24 V.DC. It is connected to a 220 V.AC feed from the frequency unit, and consists of a transformer (T1), two diodes (D1,2) and a capacitor (C2).

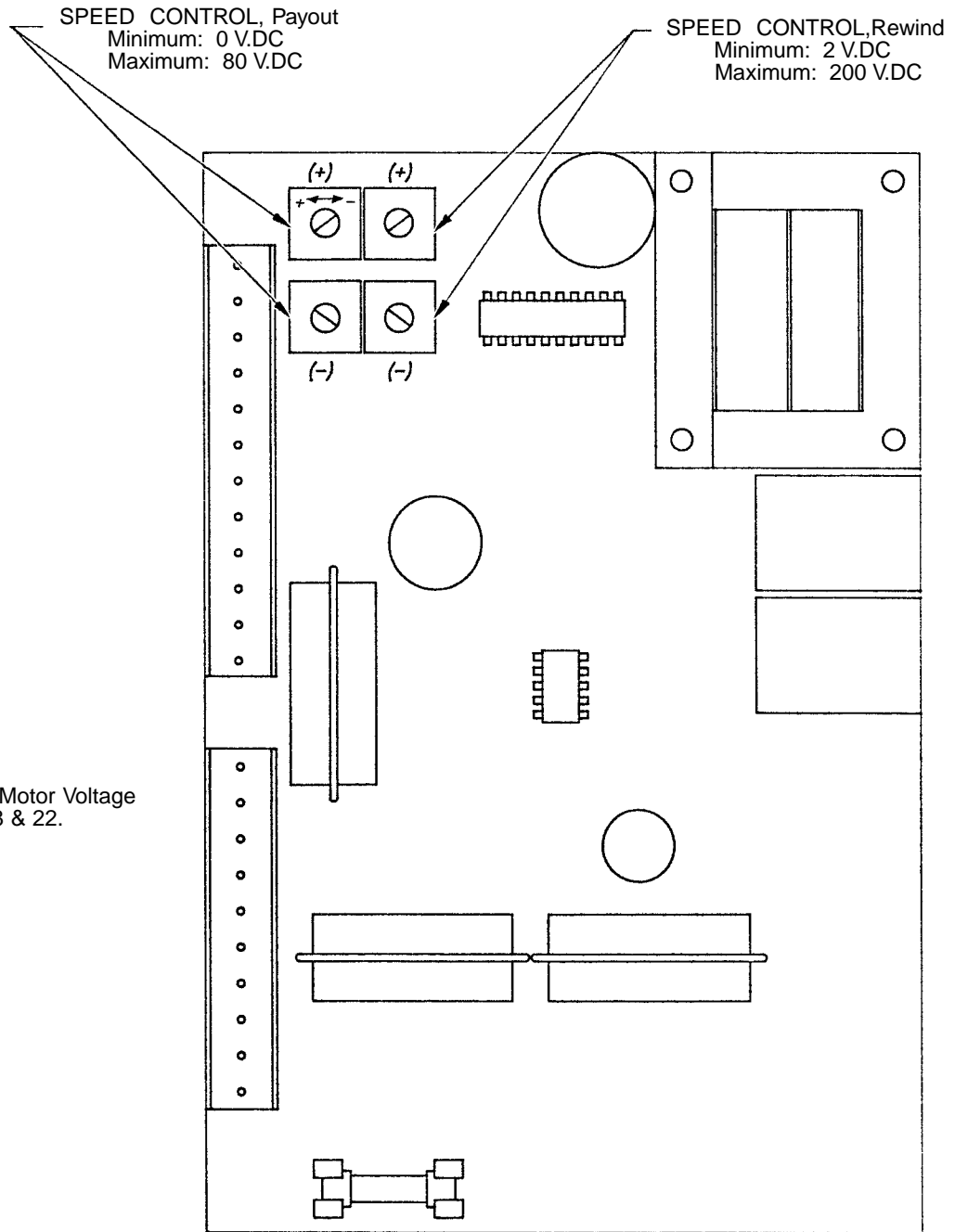

SPEED CONTROL, Payout
 Minimum: 0 V.DC
 Maximum: 80 V.DC

SPEED CONTROL, Rewind
 Minimum: 2 V.DC
 Maximum: 200 V.DC

Measure Motor Voltage
 at Pins 18 & 22.

PAY-OUT MOTOR BOARD

SPEED CONTROL
Minimum: 0 V.DC
Maximum: 100 V.DC

Measure Motor Voltage
at Pins 15 & 16.

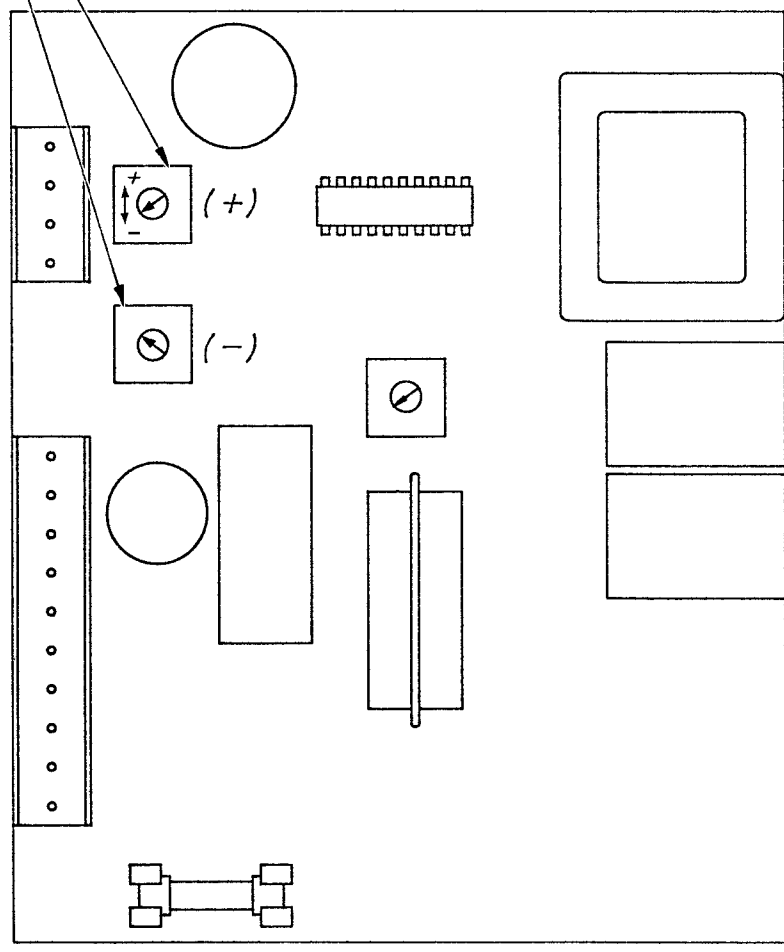

TAKE-UP MOTOR BOARD

Female Connector

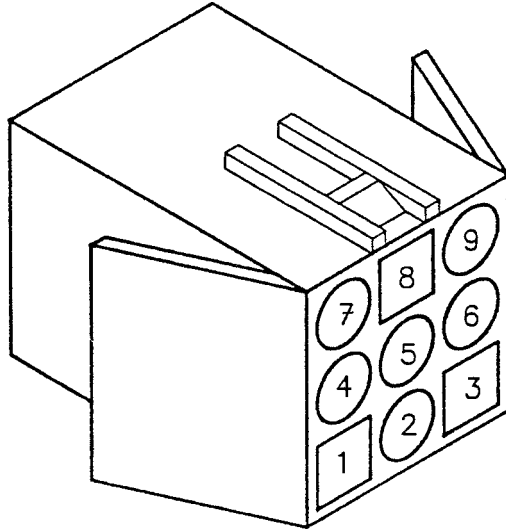

2 & 5: Micro

4 & 7: L.D.R.
(Light Dependent Resistor)

6: L.E.D. +
7: L.E.D. -
(Light Emitting Diode)

Male Connector

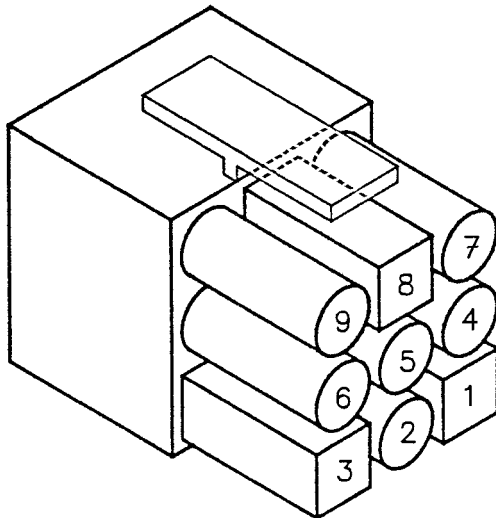

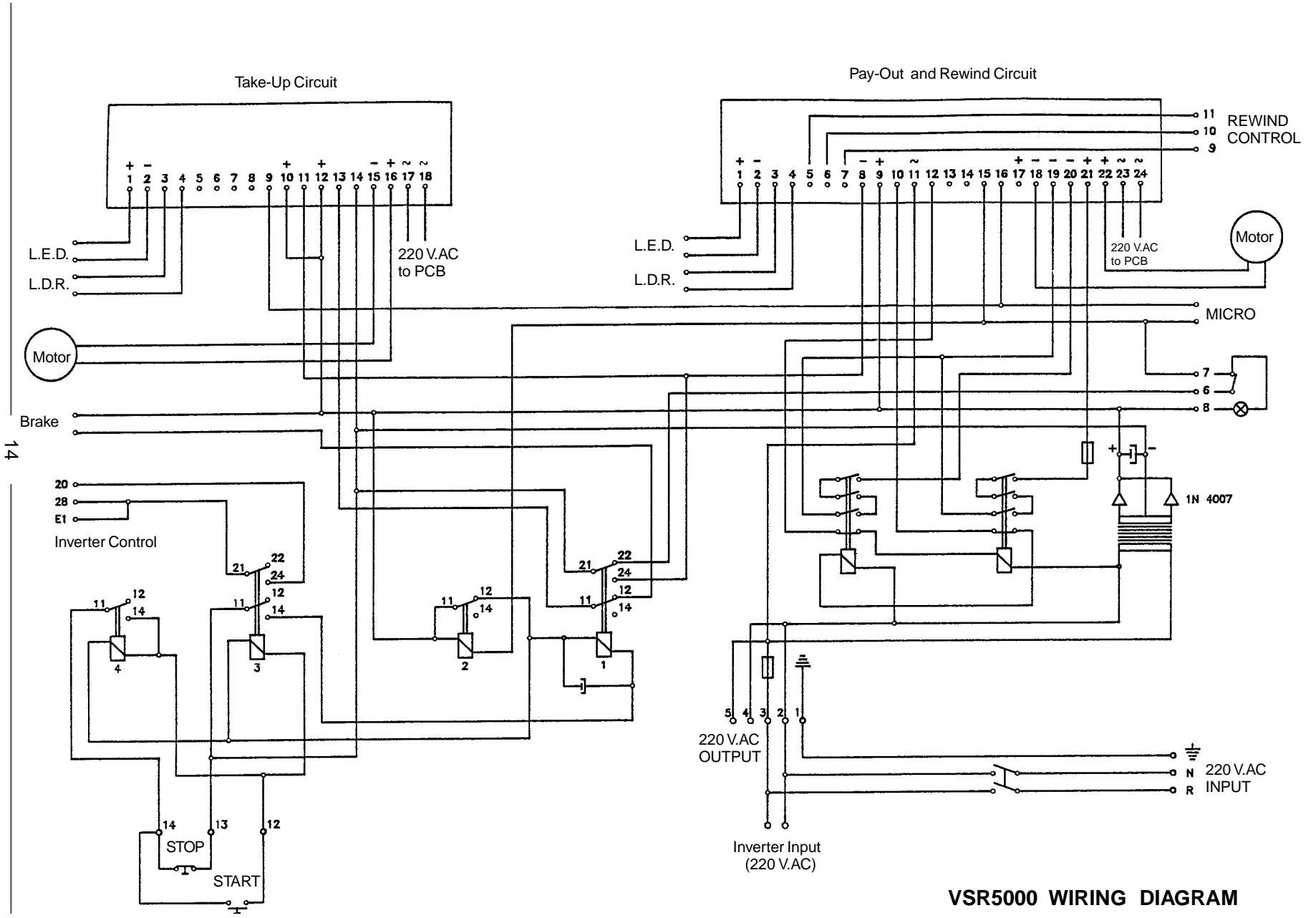

14

VSR5000 WIRING DIAGRAM