

SPA-1 AUTOMATION

Strong No. 52-70113

THE SPA-1 CONTROLLER is a basic automation device designed for auxiliary projection booth functions such as presentation of advertising footage and trailers. Pressing the S2 START switch energizes the projector motor and ignites the lamphouse. A cueing foil, applied by the operator on the inboard (non-soundtrack) edge of the film at the desired "Picture Start" point, opens the changeover douser. In the event of a film split or break during the performance, the failsafe switch will open and shut off the projector motor and extinguish the lamphouse. A second cue, placed on the outboard (soundtrack) film edge at the end of the desired footage, closes the changeover douser. Film runout will open the failsafe switch and shut off the projector motor and extinguish the lamphouse.

A MANUAL "MOTOR" SWITCH (S1) allows turning the projector motor ON and OFF independently from the automation. The lamphouse MANUAL mode permits bulb ignition without energizing the automation; see the lamphouse or console instruction manual.

THE SPA-1 makes no provision for sound switching or changeover.

CUE PLACEMENT

REMOVE all traces of foreign cues which may have been left on the film by prior exhibitors. Use film cleaner as required to remove residue of the foil tape.

THE CUEING FOIL TAPE must be applied to the outer edge of the film outside the perforations. It is necessary to wrap the tape around the edge of the film to allow conduction through the tape between the pickoff surface and the sprocket. The length of foil tape applied to the film should be approximately 1½ inches (38 mm); at least 1" (25 mm) but not exceeding 2" (50 mm).

THE INBOARD CUE, used to open the changeover douser and allow the presentation to begin, should be applied to the outer edge of the inboard (non-soundtrack) side of the film at least 8 feet (2.4 m) from the point at which the HEAD protection leader is framed. This distance is required to allow the projector shutter to reach speed before the changeover douser opens. The second cue, used to close the changeover douser, should be applied to the outboard (soundtrack) edge of the film at the end of the footage approximately 1 foot (30 cm) before the TAIL protection leader.

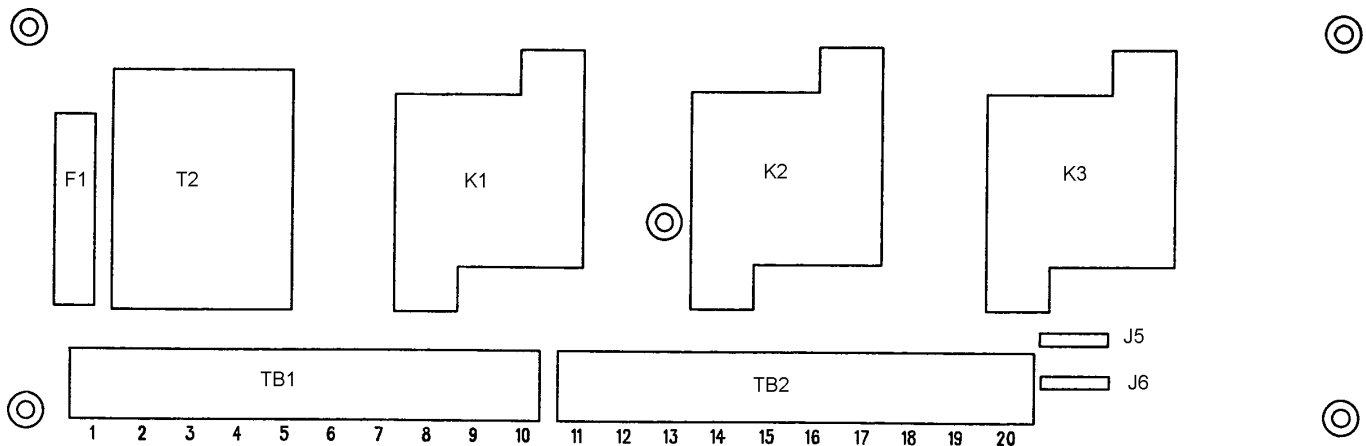

INSTALLER CONNECTIONS

TB1

- 1 AC Input, 115 V.AC Phase
- 2 AC Input, 115 V.AC Neutral
- 3 Projector Motor, 115 V.AC Phase
- 4 Projector Motor, 115 V.AC Neutral
- 5 Dry Contact, "Lamp ON"
- 6 Dry Contact, "Lamp ON"
- 7 Manual MOTOR Switch (S2)
- 8 Manual MOTOR Switch (S2)
- 9 Changeover CLOSE, 115 VAC Phase
- 10 Changeover OPEN, 115 V.AC Phase

TB2

- 11 Common; Changeover & Cue Detector
- 12 Cue Detector, Red
- 13 Cue Detector, Green
- 14 Dry Contact, Failsafe
- 15 Dry Contact, Failsafe
- 16 Dry Contact, START Switch (S2)
- 17 Dry Contact, START Switch (S2)
- 18 Ground
- 19 Switch, Changeover OPEN
- 20 Switch, Changeover CLOSE

NOTE: Terminals TB2-19 & 20 parallel terminals TB2-12 & 13 and permit installation of bypass switches (not supplied by Strong) to control changeover operation.

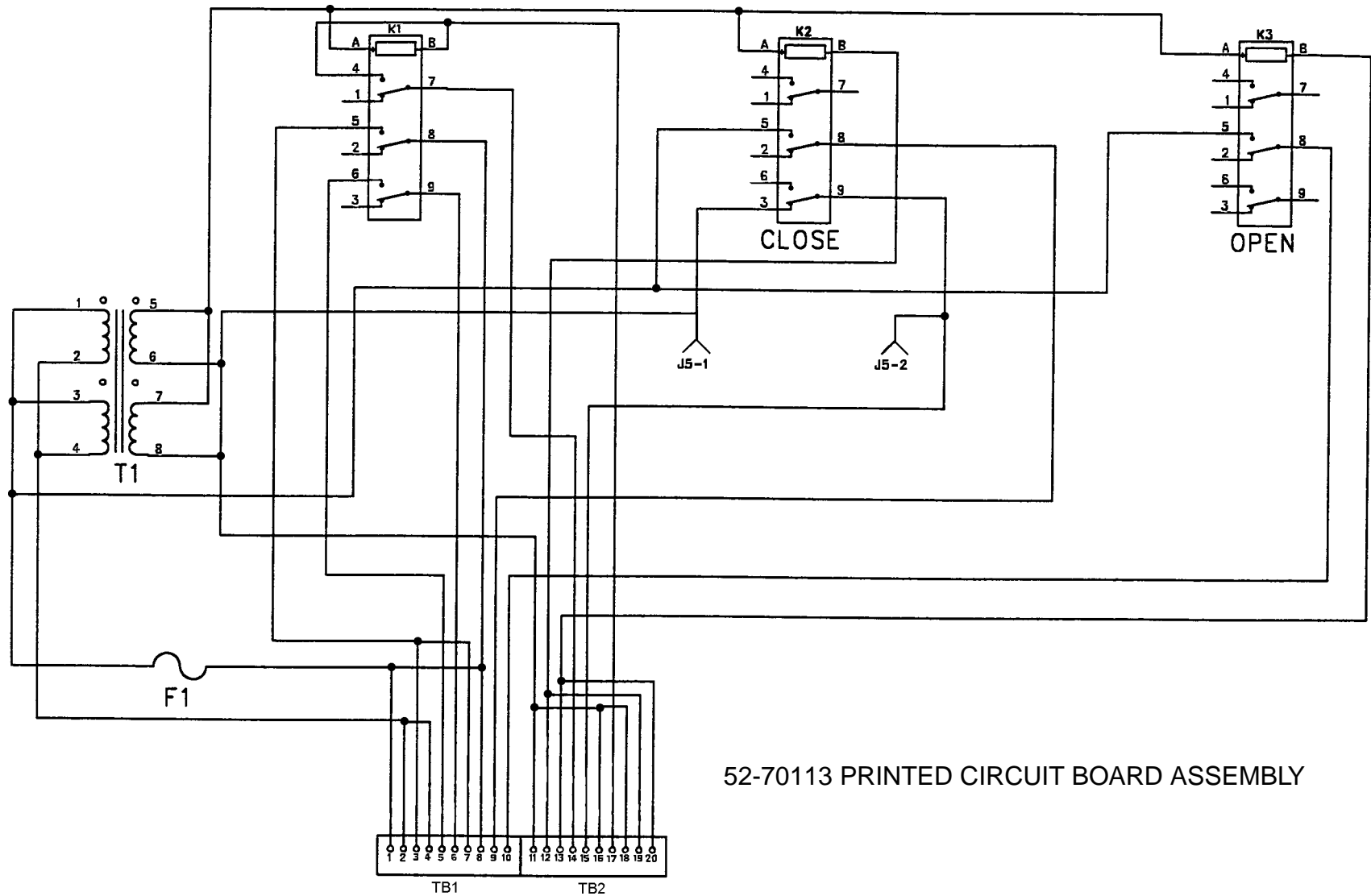

52-70113 PRINTED CIRCUIT BOARD ASSEMBLY

F1	21-21016	Fuse, 1 Amp. 250 V.	PCB	51-72028	PC Board (less Components)
J5,6	41-62081	Connector	T1	51-46003	Stepdown Transformer
K1,2,3	21-45017	Relay, 12 V.AC Coil	TB1,2	21-62052	Terminal Strip, (10) Position
-	21-40002	Relay Socket			

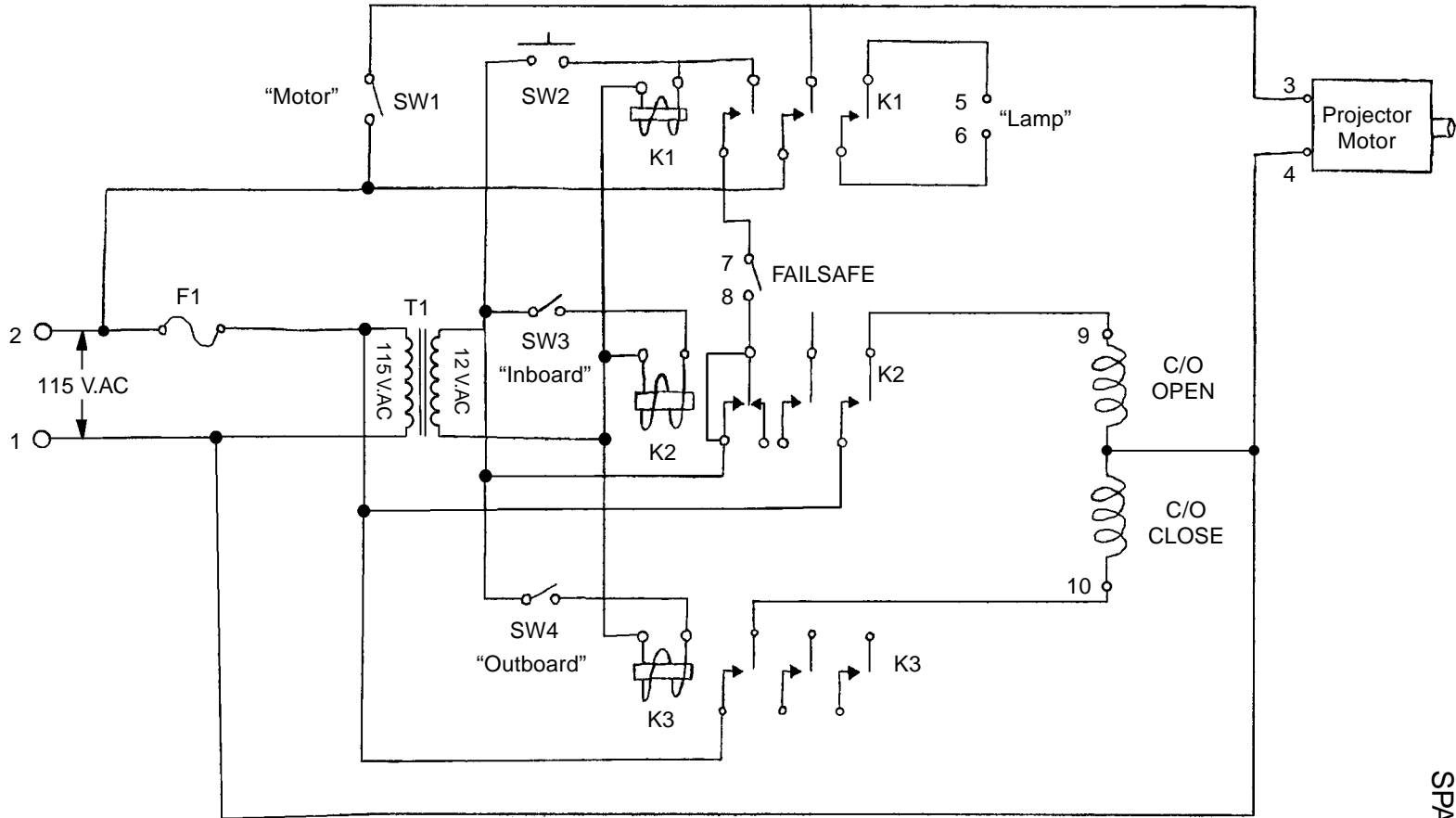

SPA-1 SCHEMATIC