

INSTRUCTION MANUAL

XENON POWER SUPPLY

Compact Model

110 Volt Type 62-80114

Issue 4/99



STRONG INTERNATIONAL

a division of Ballantyne of Omaha, Inc.

4350 McKinley Street

Omaha, Nebraska 68112 USA

Tel 402/453-4444 • Fax 402/453-7238

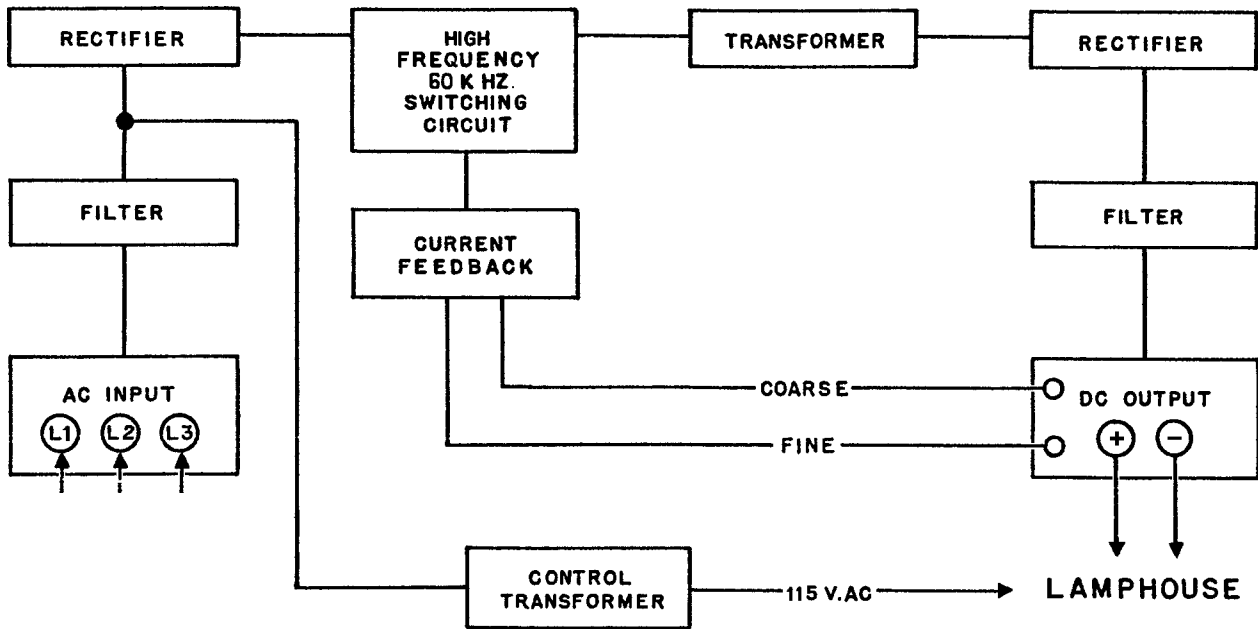

SEE "INSTALLATION" INSTRUCTIONS

PREFACE

THE STRONG INTERNATIONAL switching power supply Type 62-80114 is designed to operate a xenon bulb in all theatrical lighting applications for Strong lamphouses. This unit will operate all xenon bulbs rated from 700 to 1600 watts throughout their full operating ranges (18-22 V.DC, 30-70 A.DC). The power requirement for this unit is 110 (90-140) V.AC, 30 amperes single phase.

INCOMING LINE POWER is transformed from 110 volts AC to a low voltage, high current DC output. The incoming AC line is filtered to eliminate noise and is then converted to DC. This DC voltage is switched on and off by a solid state switching circuit, and converted to a 60 kHz. square wave. The square wave is fed into output transformers to provide low voltage and high current. Rectifiers convert the 60 kHz. signal to DC, and the output is filtered to eliminate noise and ripple. Output to the xenon bulb is adjustable through use of potentiometers.

PROTECTIVE CIRCUITS include a high temperature limit switch and under- and overvoltage detection. The thermal switch will open and interrupt power supply operation if internal temperatures exceed 175° F. (80° C.). A drop in AC line voltage, reducing AC supply to inadequate levels, or a high voltage AC spike, will also disable the power supply until the voltage is corrected.

A MULTI-PIN MS RECEPTACLE is standard on units supplied for use with Strong follow spotlights and projection consoles. A lamphouse termination panel may be ordered as an option for motion picture or studio applications using Strong lamphouses without the corresponding MS plug.

NOTICE



REFER ALL SERVICING of this unit to an authorized Strong International Equipment Dealer. The 62-80100 Switching Xenon Power Supply employs solid state circuitry requiring sophisticated diagnostic equipment not generally available to field service personnel. Hazardous high voltages exist within the power supply cabinet.



INSTALLATION - OPERATION



CAUTION: This equipment operates at hazardous voltages, and should be operated by qualified, trained personnel *only*. Do not remove power supply cover panels when the unit is energized.



When positioning the power supply, allow several inches clearance around the power supply cabinet for unobstructed air flow. If the intake or outlet grilles are blocked, thermal switches will shut the unit off to prevent heat damage.

Connect the lamphouse DC and control leads to the output side of the power supply prior to connecting to AC power. Lamphouse to power supply connections, when not terminated in a MS plug, are illustrated on the INTERCONNECTION DIAGRAM in the lamphouse instruction manual. Make certain the lamphouse ground lead is connected.

Power leads run to the unit must be of the correct size and type to conform to local codes. Shield in conduit as required. The power supply will not energize until the circuit breakers on the side of the cabinet are placed in the ON position.

A THREE-CONDUCTOR POWER CORD, terminated with a 115 volt, 30 ampere three-prong plug is included with the 110 volt power supply. If the plug is replaced with another type, make certain the replacement plug is in compliance with local codes. This unit *must* be connected to a commercial, 30 ampere receptacle.

See the warranty information packed with the xenon bulb for correct operating current. Do not, at any time, exceed the maximum current level specified by the bulb manufacturer.

Current output to the bulb is set through use of the adjustment potentiometer(s). If installed in a Strong Xenon Projection Console, the adjustment potentiometer (62-70032) is generally remoted to the console control panel. When the remote option is not utilized, a potentiometer printed circuit board assembly (62-70028) is connected directly to the current control receptacle.

Check the lamphouse ammeter upon the first bulb ignition, and adjust the current control potentiometer to set the desired bulb current. On Strong projection consoles, this potentiometer is usually remoted to the lamphouse control panel adjacent to the ammeter. Rotate the potentiometer clockwise to increase current, or counterclockwise to reduce current. When the potentiometer printed circuit board assembly is used in place of a remote control assembly, a second (fine) adjustment potentiometer is included for output changes in small increments. The PC board is marked *coarse* and *fine* to identify the (2) potentiometers.

The lamphouse control circuit is factory prewired. Terminals 2 & 4 supply 110 V.AC to the lamphouse. After completing the lamphouse interlock circuit, the 110 V.AC returns to the power supply on wires 5 & 6 to energize the control printed circuit board at plug PL5 upon closure of the LAMP ON switch. The same circuit (5 & 6) energizes the AC lamphouse igniter.

The DC Pulse Igniter used in some Strong lamphouses does not require the AC control voltage supplied on 5 & 6, but will be actuated from the high DC open circuit (“no load”) voltage normally generated by the power supply. The DC voltage will fall to a lower sustaining level (20 - 35 V.DC) after the xenon bulb ignites, and the DC Pulse Igniter will cease operation when the DC voltage drops below 130 V.DC.

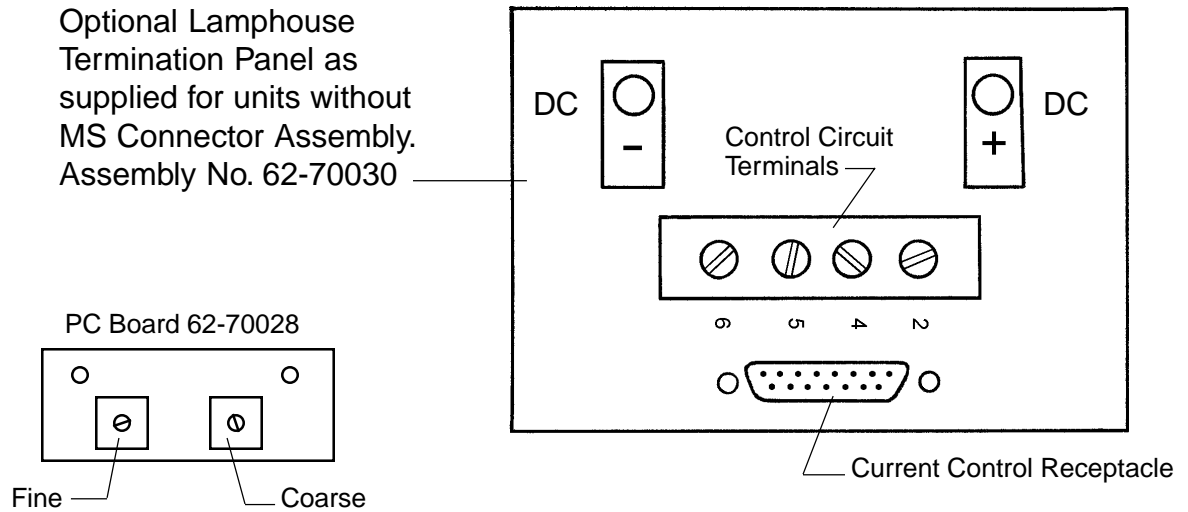

MAINTENANCE

The power supply requires very little service to insure correct operation. Periodically check all electrical connections for tightness and condition, especially those in the DC circuit. Discolored terminals may indicate oxidation which will increase resistance.

Clean the ventilation inlet and outlet grilles on a regular basis to insure good air flow. Thermal switches mounted to the power supply will interrupt operation of the power supply in the event of overheating.

The blower motors are permanently lubricated. The 62-80100 power supply includes (2) blowers and requires operation of both *fully functional* blowers for correct operation. In the event of a blower failure, a replacement blower must be installed immediately.

Service interruptions because of low (below 90 V.) or high (over 140 V.) AC input require adjustments to the AC supply line. To protect the equipment, voltage level protection *cannot* be bypassed.

INDICATOR LIGHTS

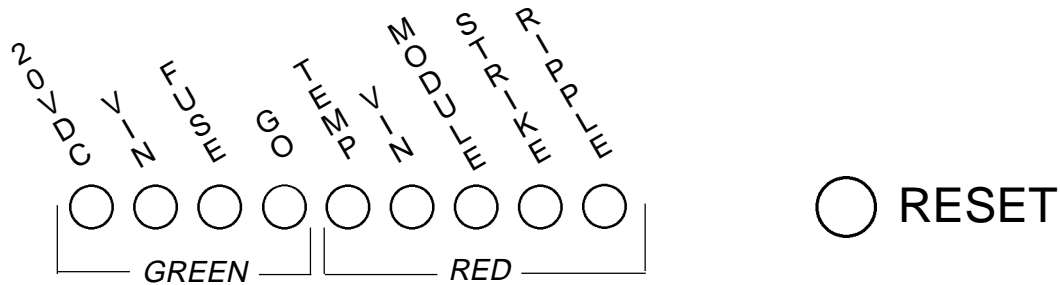

WHEN ALL FOUR of the green indicator lights are glowing, the power supply is operating trouble-free. One or more red lights, when glowing, indicates that a problem exists, and disables operation of the power supply. The red light(s) latches and remains glowing until the RESET button is depressed after the problem has been corrected.

GREEN LIGHTS:

- 20 VDC:** Indicates that the control board is receiving the correct DC input.
- VIN:** Indicates that the AC input voltage is within the correct range (90-140 V.AC).
- FUSE:** Indicates that the fuses on the primary boards are good.
- GO:** Indicates that the lamphouse interlock circuit is complete, and that DC power is being applied to the xenon bulb.

RED LIGHTS:

- TEMP:** Indicates that the unit is overheated.
- VIN:** Indicates that AC input voltage is above or below the correct range (90-140 V.AC).
- MODULE:** Indicates that one or more fuses on the primary boards have opened.
- STRIKE:** Indicates that the xenon bulb is requiring an excessive number of ignition pulses.
- RIPPLE:** Indicates excessive ripple in the output current.

TROUBLESHOOTING

See Lamphouse Manual Before Troubleshooting Power Supply

Lamphouse Blower(s) Not Operating; Power Light “ON,” Circuit Breaker “ON”

1. Lamphouse interlock switch open. See lamphouse manual.
2. Three ampere circuit breaker is tripped. Press to reset.
3. Improper AC input connection. Check AC voltage at contactor terminals; should read 200 - 240 V.AC across input terminals (X, Y, Z for three phase; X & Z only for single phase).
4. Miswired output on terminals 2 & 4. Should read 100 - 120 V.AC; check wire numbers.
5. Defective circuit breaker. Check resistance across circuit breaker CB1 with supply OFF; should measure 0 Ohms. Replace as required.
6. Defective filter board. Check across each leg of the filter board input and output; voltage should measure 200 - 240 V.AC. Replace as required.
7. Improper AC connections in lamphouse. Check AC voltage at 2 & 4 in lamphouse; voltage should measure 100 - 120 V.AC; check wire numbers.
8. Lamphouse blower fuse blown (if applicable). See schematic in lamphouse manual.
9. Defective lamphouse blower. Check AC voltage at blower motor inputs; should measure 100 - 120 V.AC. Replace if defective.

Lamphouse Blower(s) Operate, but Power Supply GO Indicator does not glow

1. No voltage on terminals 5 & 6. Possible open interlock switch in lamphouse or power supply; check air flow and interlock switches and interlock connections.
2. Incorrect setting of lamphouse MODE (AUTO - MAN.) switch. See lamphouse manual.
3. Faulty remote or automation contact (if using lamphouse in AUTO mode).
4. No voltage on terminals 5 & 6. Check for 120 V.AC at control PC board PL5. If no voltage, check for loose connection or broken wire.
5. Defective control PC board. Check for 20 V.DC at U14 pin 2 & ground test point on power supply control board. Check for 120 V.AC on PL5. If voltages present and GO light does not glow, *consult factory*.
6. Power supply overheated (red TEMP light glowing; open thermal switches). Check for correct blower operation and unobstructed air flow in power supply cabinet. Thermal switches will open if temperatures inside the power supply cabinet exceed 175° Fahrenheit (80° Celsius).

TROUBLESHOOTING (continued)

Xenon Bulb Fails to Ignite; Blowers Operating, GO Indicator glowing

1. Defective or expired xenon bulb. Replace as required.
2. Incorrect igniter printed circuit board. Strong AC type igniters should be connected to high voltage igniter PC board (Part No. 40913, 65992B, or equivalent).
3. Check DC no load output voltage. Should measure 150 - 180 V.DC; if lower, *consult factory*.
4. Faulty DC output connection. Check and correct as required. Tighten connections securely.
5. No DC voltage output. Blown fuse on primary board; allow power supply twenty minutes (power OFF) to discharge capacitors before removing fuse. Good fuse should measure 0 Ohms; replace as required. If fuse blows repeatedly, *consult factory*.
6. Defective igniter. Allow unit to cool and attempt re-ignition. Check DC voltage at output; should measure 150 V.DC or higher. If voltage is correct, check DC connections in lamphouse and power supply; tighten securely. Attempt re-ignition; if no ping is audible in the lamphouse, replace igniter. If ping is audible, but no flash is apparent, check for lamphouse DC lead shorting to ground. If ping is heard and arc is visible between bulb electrodes, and bulb fails to ignite, replace bulb.

Xenon Bulb Goes Out During Operation (Intermittent Operation)

1. Defective or expired xenon bulb. Replace as required.
2. Fault in lamphouse interlock circuit (loose access door, inadequate exhaust draft). See lamp-house manual.
3. Power supply overheated. Check for blower operation and unobstructed air flow in power supply enclosure. Thermal switches will open if heat sink temperatures exceed 175° Fahrenheit (80° Celsius).
4. Brown-out (voltage drop) or spike (voltage surge) in AC supply. Measure AC source.

No Output Current Adjustment

1. Defective power module. *Consult factory*.

Xenon Power Supplies, Lamphouse Igniters, and other components shipped to the factory for credit, repair or repair/exchange must be returned through an authorized Strong International Equipment Dealer. Contact your Strong International Dealer for a **Return Authorization** and instructions prior to shipping any goods to Strong.

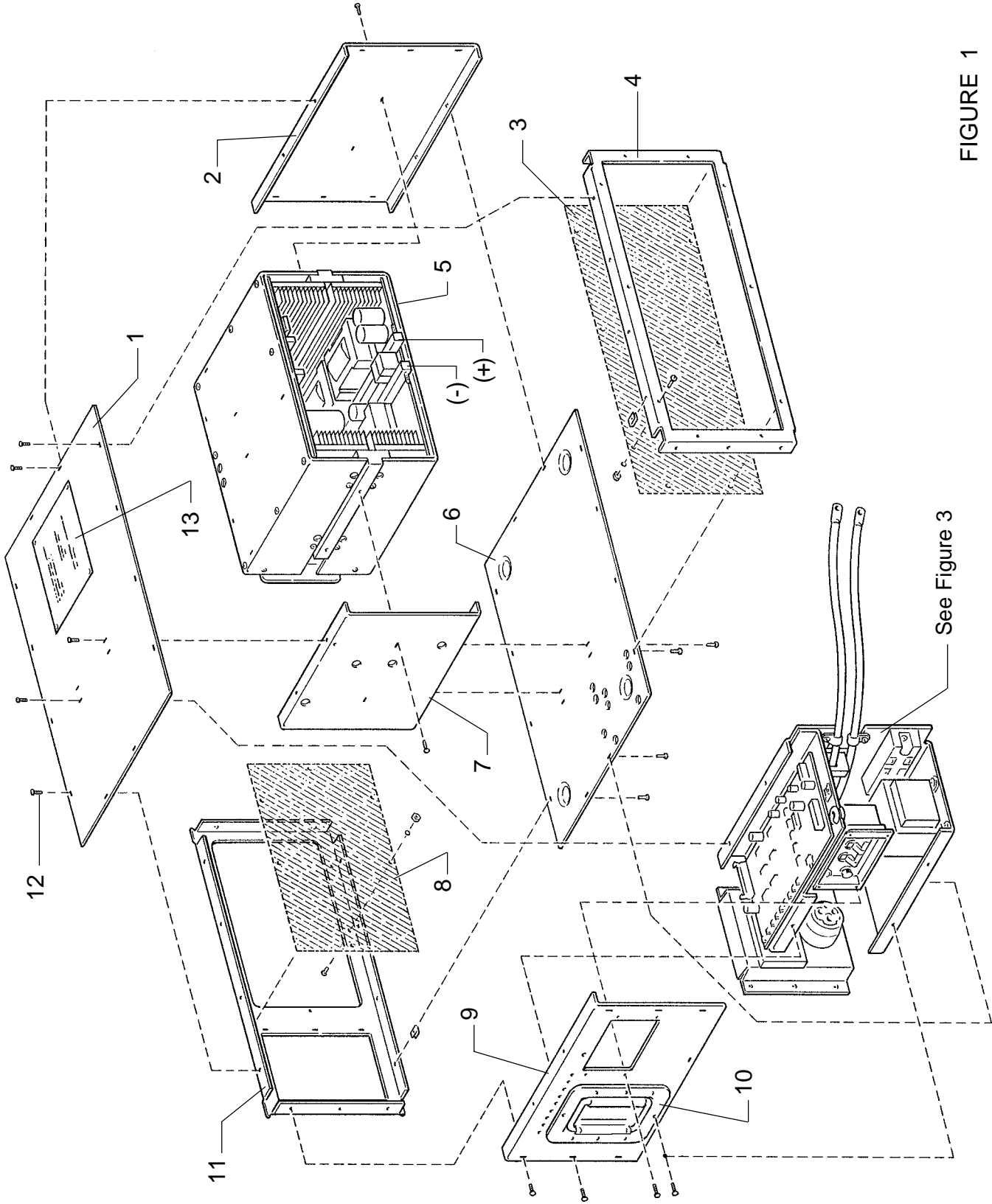

See Figure 3

FIGURE 1

PARTS LIST

Figure 1

<u>Item</u>	<u>Part No.</u>	<u>Description</u>
1	62-40121	Top Cover Panel
2	62-40095	Side Panel (Left)
3	62-40123	Vented Panel, Rear
4	62-40101	Rear Panel Bracket
5	62-80105	Power Module (See Figure 2)
6	62-40096	Base Plate
7	62-40098	Brace Panel
8	62-40102	Vented Panel, Front
9	62-40118	Side Panel (Right)
10	77271000	Handle, Spring-Loaded
11	62-40097	Front Panel Bracket
12	41-51540	Panel Mounting Screw, 8-32 x 3/8"
13	62-80036	Name & Data Plate

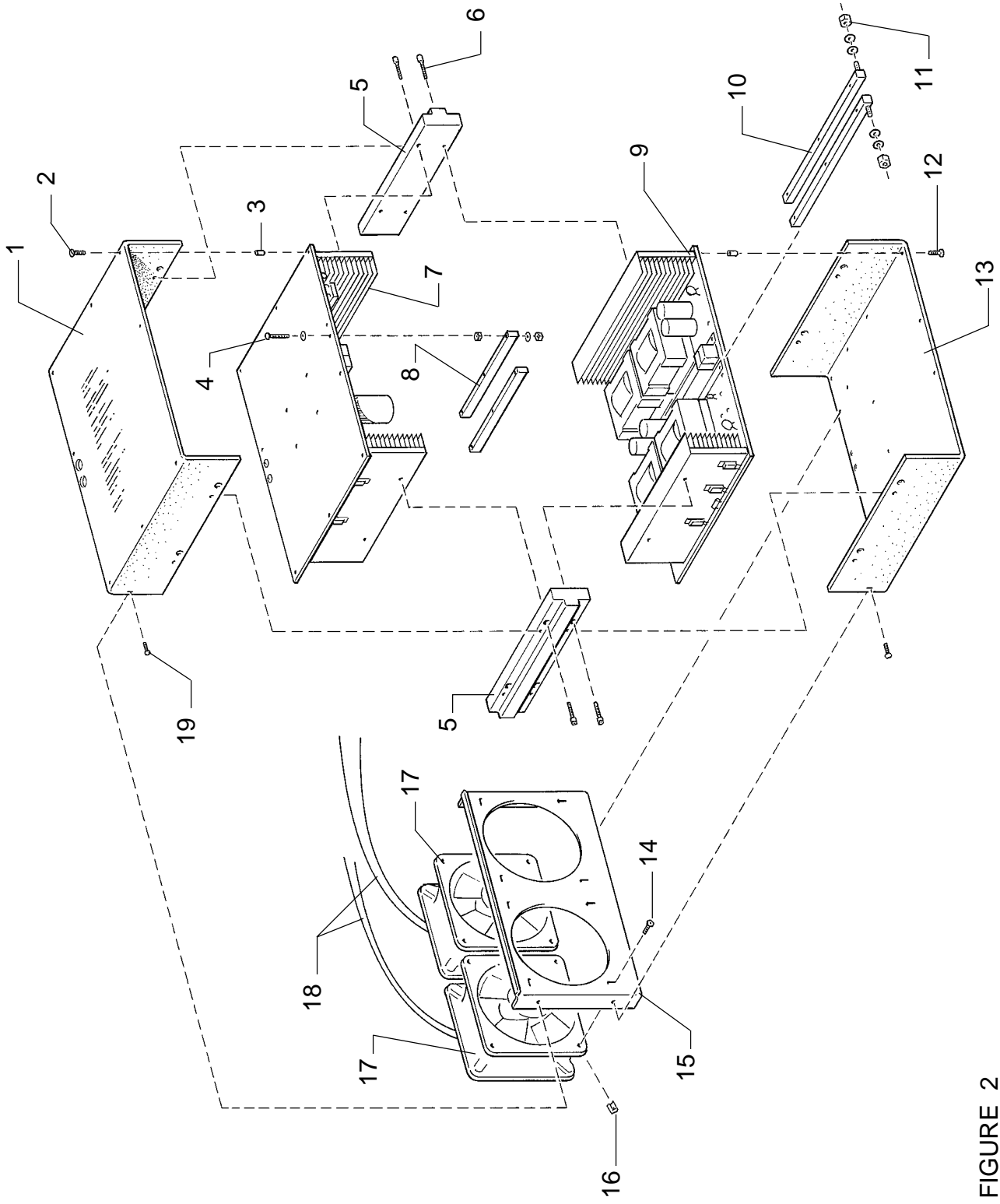

FIGURE 2

PARTS LIST

Figure 2

<u>Item</u>	<u>Part No.</u>	<u>Description</u>
1	62-00006	Upper Shield, Silk Screened
2	41-51032	Screw, 6-32 x 1/4" Bind Head
-	41-70012	Lockwasher, #6
3	61-98031	Spacer, #6 x 1/4"
4	41-51728	Screw, 6-32 x 1" Brass
5	62-20021	Insulated Support
6	41-51197	Screw, 8-32 x 1/2" Socket Head
7	62-70015	Primary Module Assembly
-	81-21001	Fuse, 15 Ampere (2 req'd.)
8	62-20027	Primary Buss Bar
9	62-70020	Secondary Module Assembly
10	62-20028	Output Buss Bar
11	41-35060	Locknut, 1/4-20
-	61-70002	Spring Washer
12	41-51032	Screw, 6-32 x 1/4" Bind Head
13	62-40093	Lower Shield
14	41-51413	Screw, 6-32 x 5/8" Phillips Head
15	62-40094	Fan Panel
16	61127000	Fan Clip, 6-32
17	61-98002	Fan, 115 V.AC, 50/60 Hz.
18	88253000	Cord & Molded Plug
19	41-51540	Screw, 8-32 x 3/8" Phillips Head

Items 21 & 22 *not used* on 110 volt models; Order 61-40010 Plug or 62-70036 Cord & Plug Assembly

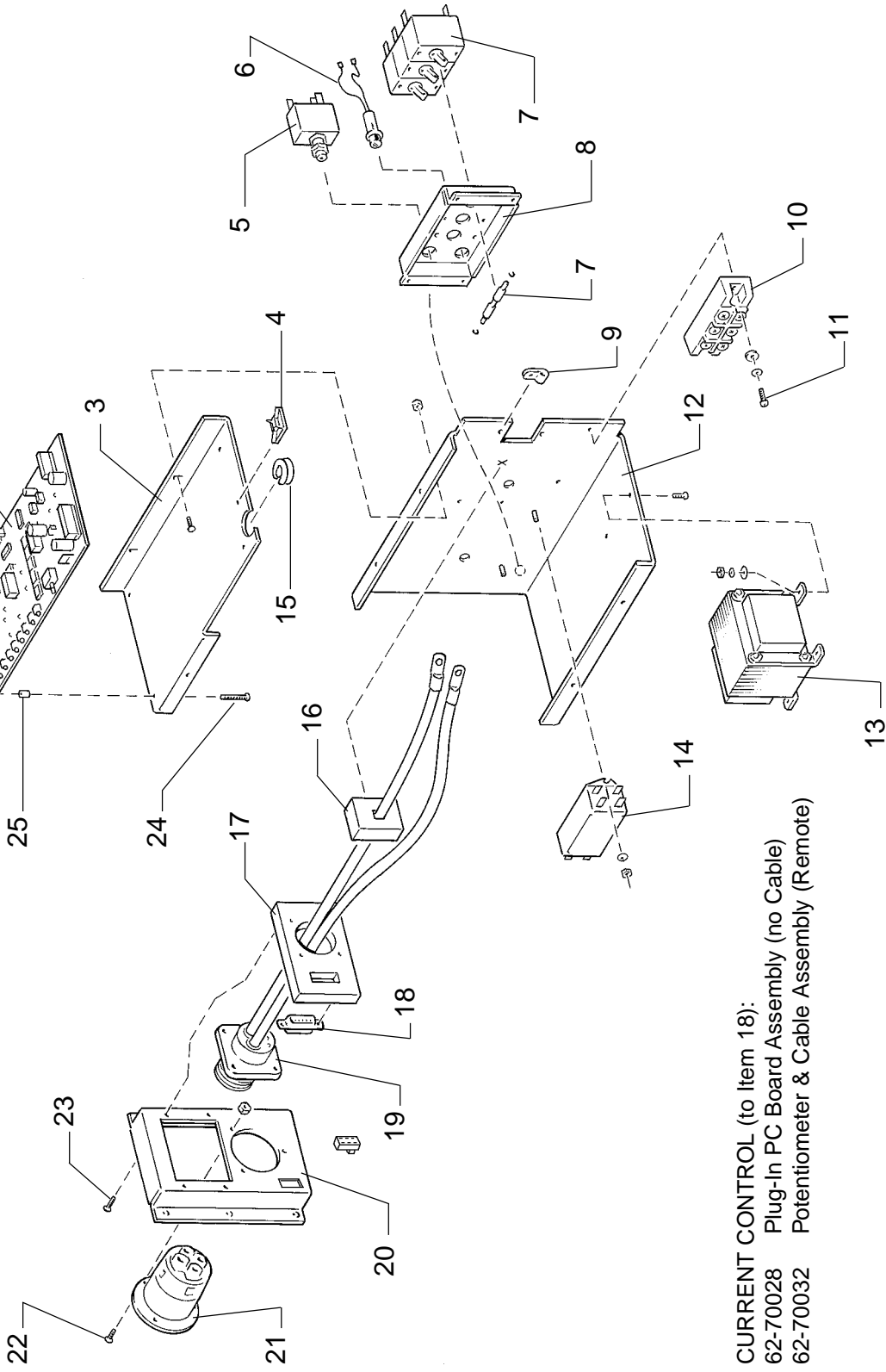

CURRENT CONTROL (to Item 18):
 62-70028 Plug-In PC Board Assembly (no Cable)
 62-70032 Potentiometer & Cable Assembly (Remote)

FIGURE 3

PARTS LIST

Figure 3

<u>Item</u>	<u>Part No.</u>	<u>Description</u>
1	61-71013	Ribbon Cable Assembly
2	61-72015	Control Printed Circuit Board Assembly
3	62-40120	Chassis, Control PCB
4	21-10003	Wire Tie Mount, Self-Adhesive
5	61-61002	Circuit Breaker, 3 Ampere 1 phase
6	61-30001	Indicator Light, Red
7	61-61001	Circuit Breaker, 30 Ampere 3 phase
8	62-40116	Circuit Breaker Mounting Panel
9	41-10029	Cable Clamp, Nylon
10	61-17001	Diode Bridge
11	41-51078	Screw, 8-32 x 7/8" Bind Head
12	62-40122	Chassis Bracket
13	62-70023	Stepdown Transformer, AC Control
14	61-98035	Line Filter
15	41-98045	Grommet
16	62-70026	LEM Harness
17	62-40128	MS Receptacle Mounting Panel
18	61-13007	Amphenol Plug, (15) Pin
19	62-70025	MS Connector, Wired Assembly
-	88319000	MS Receptacle, (14) Pin Female
20	62-40116	Mounting Plate
21	61-40007	AC Input Receptacle, 30 Ampere Hubbell
22	41-51540	Screw, 8-32 x 3/8" Phillips Head
23	41-51413	Screw, 6-32 x 5/8" Phillips Head
24	41-51021	Screw, 4-40 x 1/2" Bind Head
25	51-56002	Nylon Spacer
26	41-35003	Hexnut, 4-40
-	41-70011	Lockwasher, #4

NOT SHOWN

62-70021	Wire Harness Assembly
62-70030	Lamphouse Termination Panel (see Page 3)
62-40109	Cover, Lamphouse Termination Panel
61-98039	Strain Relief Bushing, Cover
41-35088	Locknut for Bushing

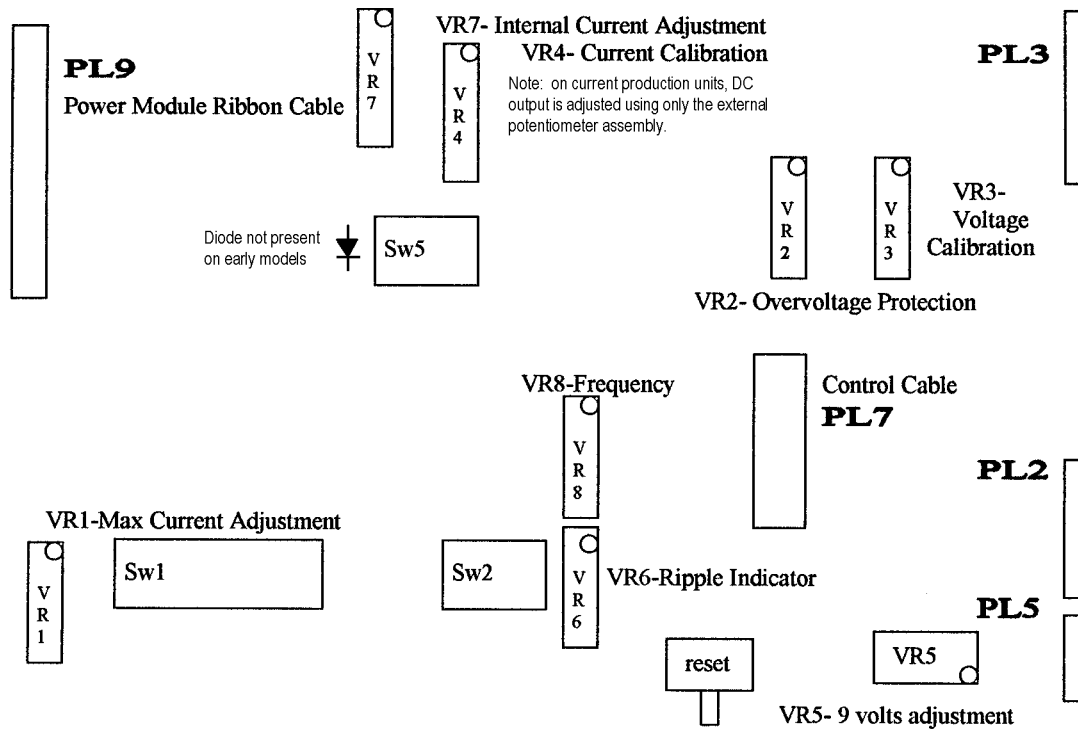

NEG
○
○
POS

Normal Switch Setting

- SW1**
- on 1. (a) Master Enable--- If **OFF** will disable SW1 2 thru 5
 - on 2. (b) Aux. Volts Good
 - on 3. (c) Input Volts Good
 - on 4. (d) Power Section Good
 - on 5. (e) Xenon On
 - on 6. (f) Master Override- If **OFF** will allow supply to operate
 - off 7. (g) Short Circuit---If **ON** will shut supply off when the output is shorted.
 - off 8. (h) Not used
- If switches are **ON**, unit will operate only if L.E.D.'s light.
- SW2**
- on 1. (a) Master Inhibit---In the **OFF** position--will disable switches SW2-2, SW2-3 and SW1-7
 - on 2. (b) Thermal Inhibit---In the **ON** position--will shut supply off, if too hot.
 - off 3. (c) Open circuit, short circuit or strike failure- If **ON** position-- will turn power supply off.
 - on 4. (d) Selects the external Current Control
- SW5**
- off 1. (a) Overvoltage shutoff--- If **ON** -will turn power supply off if voltage goes high
 - on 2. (b) Selects local Current control --**On** is for control at PCB. **OFF** is for External Control.
 - on 3. (c) Selects local master---Must be On unless the power supply is a slave unit.
 - off 4. (d) Remote master---Must be turned on if unit is a master and there are slaves connected to it.

PL7	PL2	PL3	PL 5	DB 15 Connector
Pin #	Pin #	Pin #	Pin #	Pin #
1. Com signal	6. } 9 VAC	1. -1.2 V	1. 110 V common	1. Com Signal
2. V signal (20 mv/v)	7. }	2. +20 V	2. 110 V go signal	2. I Signal (20mv/a)
3. I signal (20 mv/a)	9. } 18 VAC	3. Com. signal		3. GO Signal Input
4. 9v power return	10. }	4. DCCT signal V		4. Power Section Fault
5. Go signal input (+9v)		5. I DCCT signal		5. Inhibit Fault
6. +9v out		6. } Master/		6. (not used)
7. Power Section fault		7. } Slave		7. +9 V.
8. Enable fault				8. +9 V. Return
9. Inhibit fault				9. V Signal (20 mv/v)
12. I adjust fine				10. +9 V. Return
13. +9v signal				11. +9 V.
14. I adjust course				12. Enable Fault
				13. (not used)
				14. I Adjust Fine
				15. I Adjust Coarse

FIGURE 4

CONTROL PC BOARD, Component Functions

